

MAD E L[®]

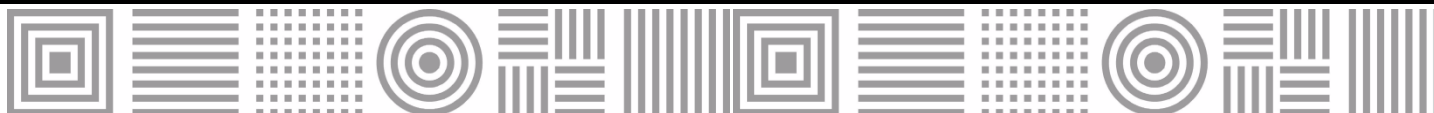

WAAB 4-WAY

Active chilled beam with 4-way



MAD E L[®]

The **WAAB 4-WAY** chilled beam is an air/water induction terminal unit that simultaneously provides the supply, thermal treatment and diffusion of supply air, to set internal conditions at the desired comfort levels. Chilled beams take advantage of the excellent thermal properties of water to guarantee optimal comfort levels, with minimal power consumption.

The main heat-transferring component in the **WAAB 4-WAY** chilled beam is a battery, formed by copper tubing and aluminium fins. It also incorporates air ducts and a plenum for supplying the ventilation air, which has been pre-treated in a central air conditioning unit. The **WAAB 4-WAY** chilled beam can be supplied with connections on the side or on the top for supply air.

The unit can be adapted to modular ceilings measuring 600x600, 625x625 and 675x675 for T24 and T15 profiles. Thanks to its reduced size, it can also be installed in low-hanging false ceilings.

WAAB 4-WAY

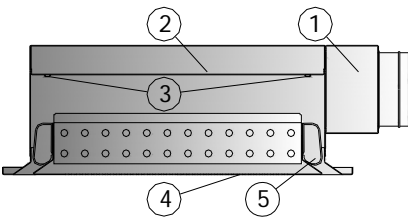

1.-Air input neck
2.-Plenum
3.-Nozzles
4.-Collapsible front panel
5.-Adjustable deflector

WAAB 4-WAY/2T/.../L/ **WAAB 4-WAY/4T/.../S/**

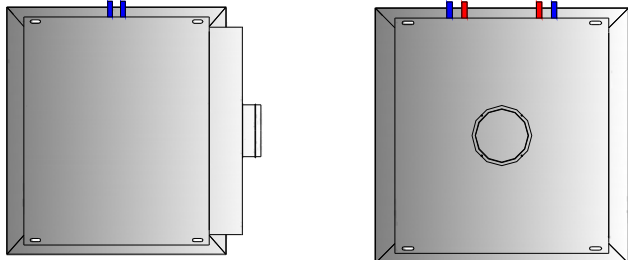
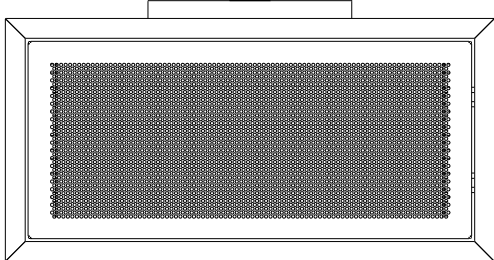
.../FC/ **.../FQ/** **.../FL/**



.../T15/ .../T24/ **.../ /**

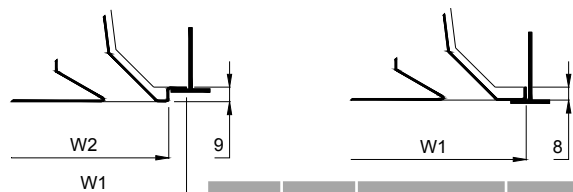

W _N	/ /		T15		T24	
	W ₁	W ₁	W ₂	W ₁	W ₂	
600	592	592	576	592	568	
625	620	620	604	620	596	
675	670	670	654	670	646	

CLASSIFICATION

WAAB 4-WAY Beam for supply air.

.../L_N/ Nominal Length (600 or 1200).

.../2T/ 2-tube battery

.../4T/ 4-tube battery.

.../LD/ Right side connection.

.../LI/ Left side connection.

.../SD/ Right top connection.

.../SI/ Left side connection.

.../T15/ Support for dropped panel, 15-mm profile modular ceilings.

.../T24/ Support for dropped panel, 24-mm profile modular ceilings.

.../KS/ Small discharge nozzles.

.../KM/ Medium discharge nozzles.

.../KL/ Large discharge nozzles.

.../FC/ Front panel with circular perforations.

.../FQ/ Front panel with square perforations

.../FL/ Front panel with lineal aluminium grill.

.../TY/ Type (see pages 5,6 and 7)

ACCESSORIES

DEF Deflecting fins (see page 4)

MOUNTING

(D) Angle bracket for suspending from ceiling (see page 8)

FINISH

M9016 Lacquered white similar to RAL 9016

R9010 Lacquered white RAL 9010

RAL... Lacquered other colours RAL

MATERIAL

Galvanised steel body, ABS plastic deflective fins and battery with copper tubing and aluminium fins.

The tubes connected to the battery have a diameter of 12 mm and a thickness of 1mm, in fulfilment of the EN 1057:1996 European Standard. The battery's maximum working pressure is 1 MPa.

SPECIFICATION TEXT

Supply and installation of active chilled beam for supply air, with 4-tube battery, right side connection plenum, pre-set medium nozzles, circular perforated front panel, with deflective fins, **WAAB 600 4 WAY / 600 / 4T / LD / KM / FC / DEF**. Built in lacquered white galvanised steel **R9010**.

Brand **MADEL**.

CONSTRUCTION AND WORKING SYSTEM

WAAB 4-WAY

The ventilation air is injected through nozzles that cause the air to accelerate and force air induction in the room, through the battery. Subsequently, the two masses of air (the induced air and ventilation air) are supplied to the space that requires air-conditioning.

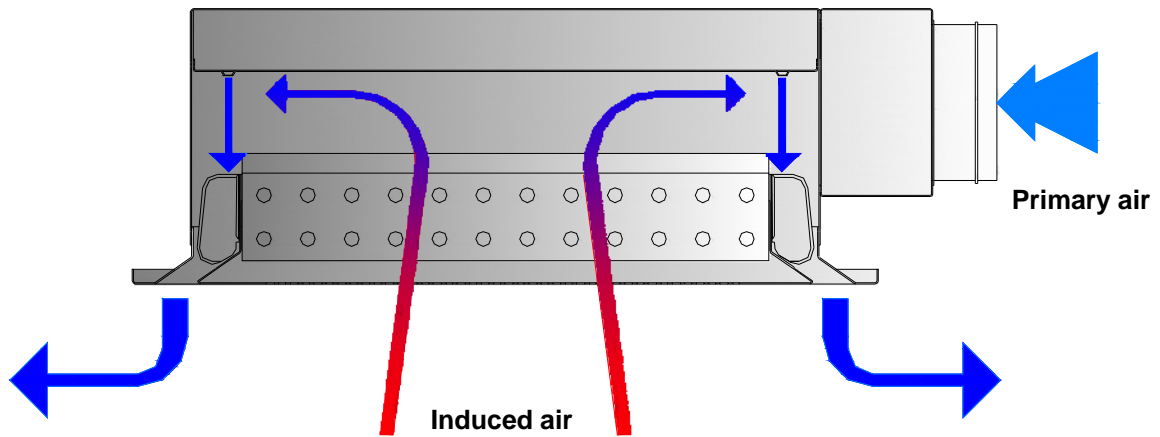

The **WAAB 4-WAY** has been designed so that it can be accessed easily for maintenance and servicing operations. For this, it has 4 fastening clips, which keep the internal frame in position. Access the clips and move them to release the internal frame, which can then be extracted.

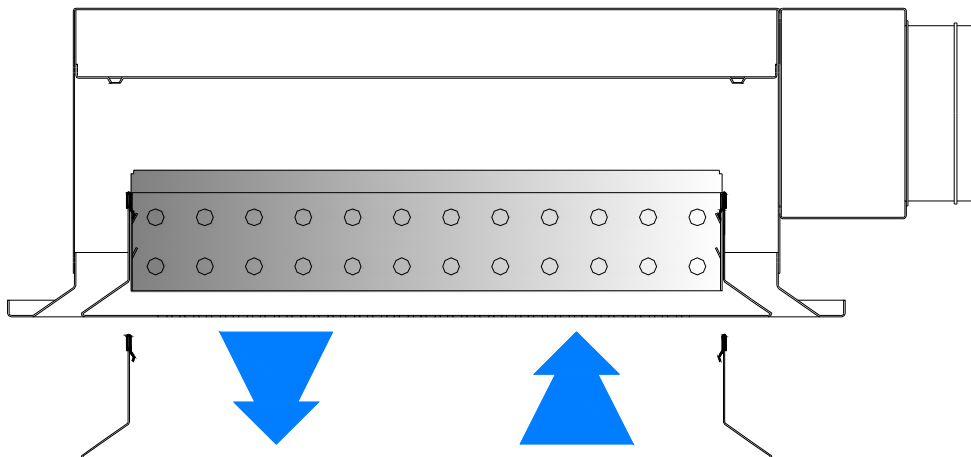

Once the internal frame of the **WAAB 4-WAY** chilled beam has been released, the airflow can be adjusted and the deflection angle changed.

Airflow adjustment

The **WAAB 4-WAY** chilled beam can be supplied with a primary airflow adjustment system. This adjustment can be made using a tube wrench with a diameter of 8 mm, making it easy to select between three air output configurations. Thus, even if the project specifications change, the primary airflow can still be readjusted using the same installation.

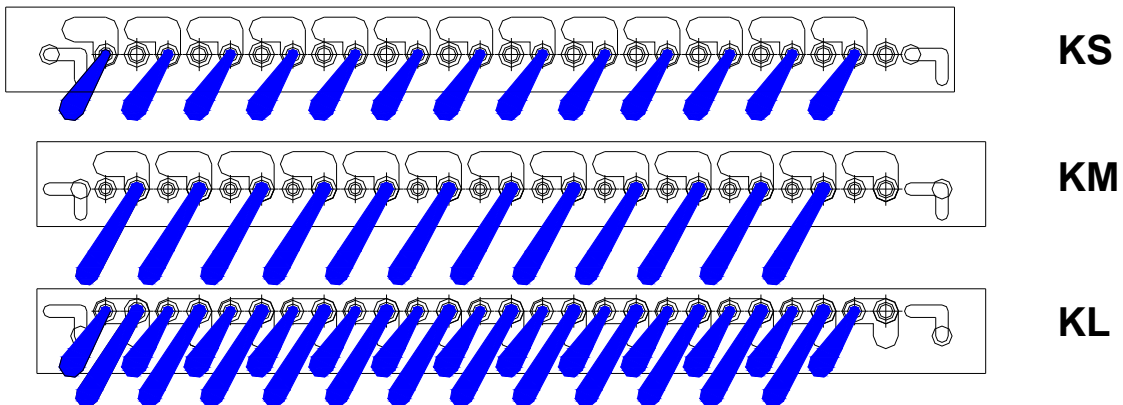

Modification of the air deflection angle.

The **WAAB 4-WAY** chilled beam can be supplied with air deflectors situated over the internal frame. The deflectors can be adjusted individually over a range of 0 to 45 °, permitting a wide variety of different air diffusion configurations in the treated area.

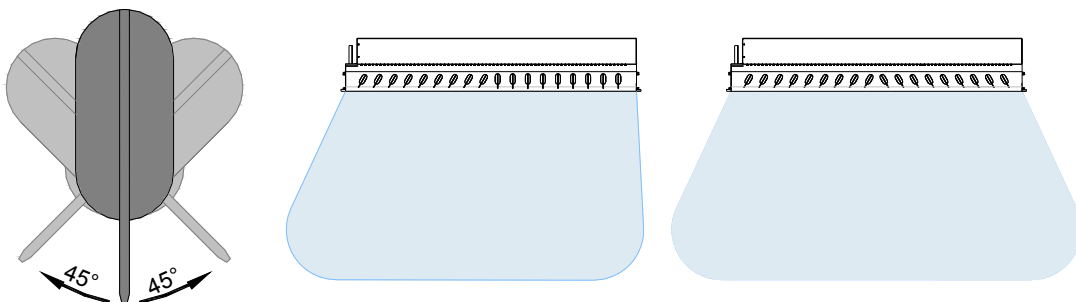

TYPES AND DIMENSIONS

WAAB 4-WAY

Side connection

Top connection

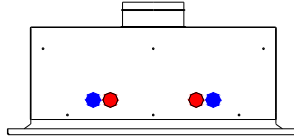
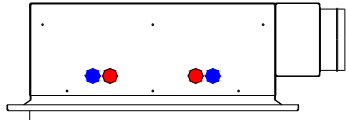

Top connection



Cold water connection



Side connection



Hot water connection

LD

SD

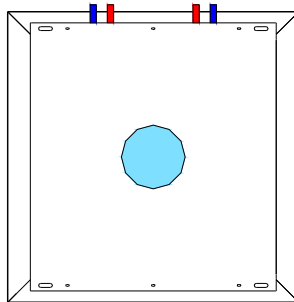
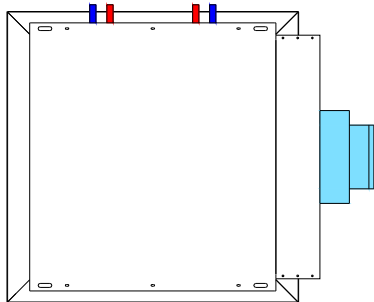

LI

SI

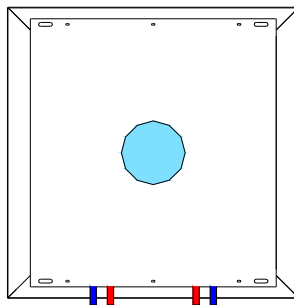
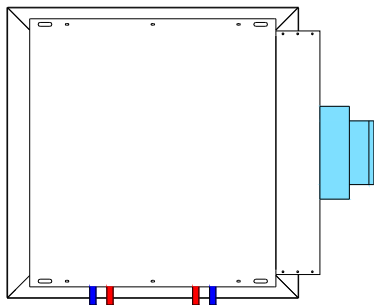

WAAB 4-WAY 600

WAAB 4-WAY 1200

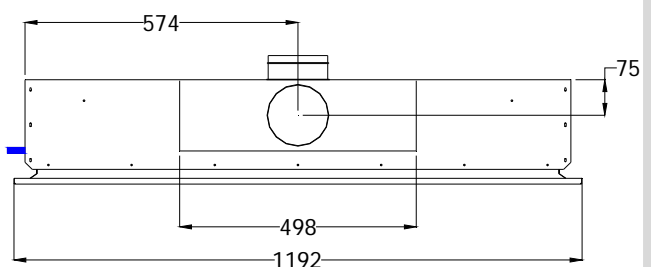
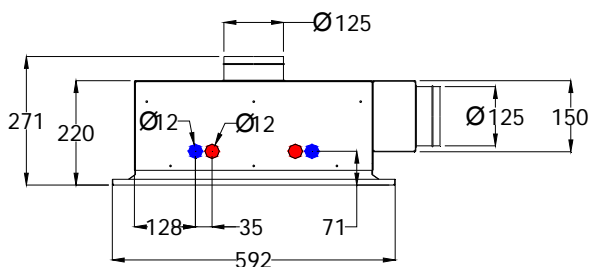
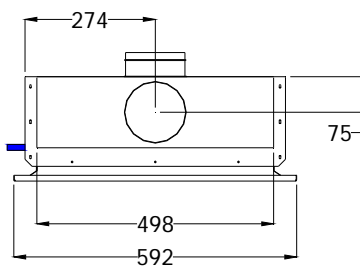
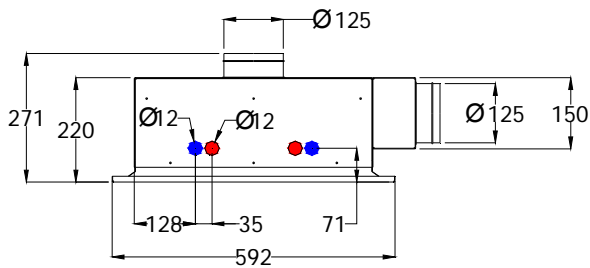

The **WAAB 4-WAYS** chilled beam incorporates a series of mounting slots on both sides. These slots have a length of 20-mm, so that the chilled beam can be easily mounted in the installation. The unit should be suspended from the structure with officially approved steel supports, cables or rods. Once suspended, the primary air duct should be connected to the plenum's neck. Likewise, the battery should be connected with solid elements, welding or quick connect fittings. Check that the hydraulic circuit has been properly emptied and that the beam is properly connected to the ventilation system to prevent air leaks.

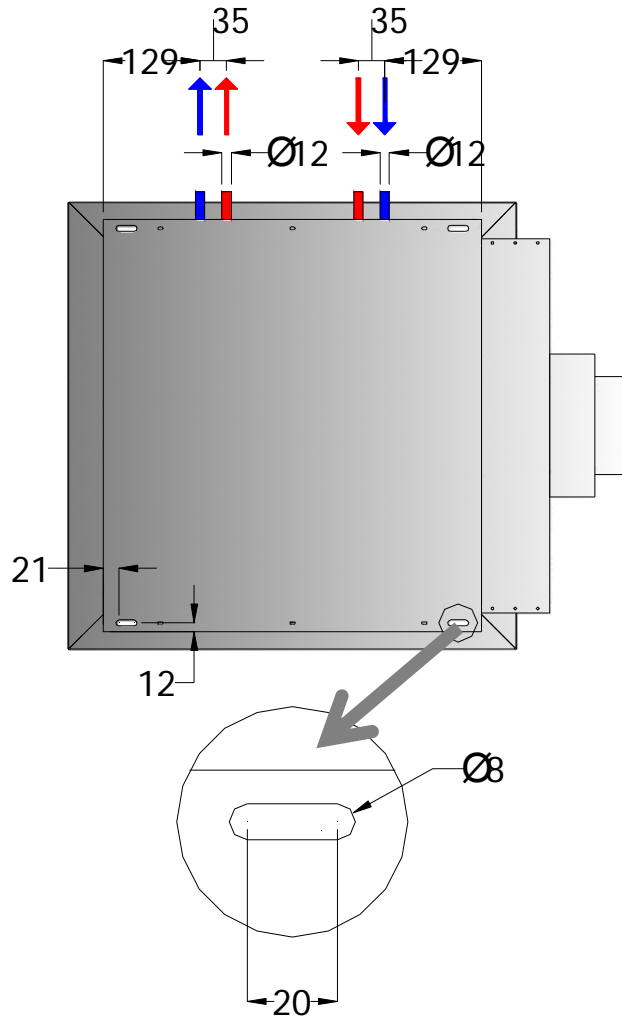

WAAB 4-WAY... / /

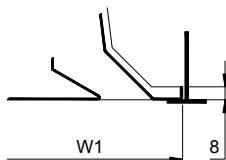

WAAB 4-WAY... / T15 /

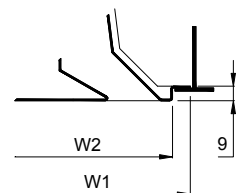

WAAB 4-WAY... / T24 /

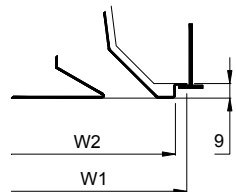

W _N	/ /	T15		T24	
	W ₁	W ₁	W ₂	W ₁	W ₂
600	592	592	576	592	568
625	620	620	604	620	596
675	670	670	654	670	646

DEFINITIONS

WAAB 4-WAY

Determining the performance/characteristics of chilled beams properly requires the performance of both thermal and diffusion tests, based on the benchmarks of standards EN 15116, EN 13182 and EN 14240.

For technical product selection uses software selection MADEL:

<http://www.madel.com/en/downloads-en/>

The benchmark is as follows:

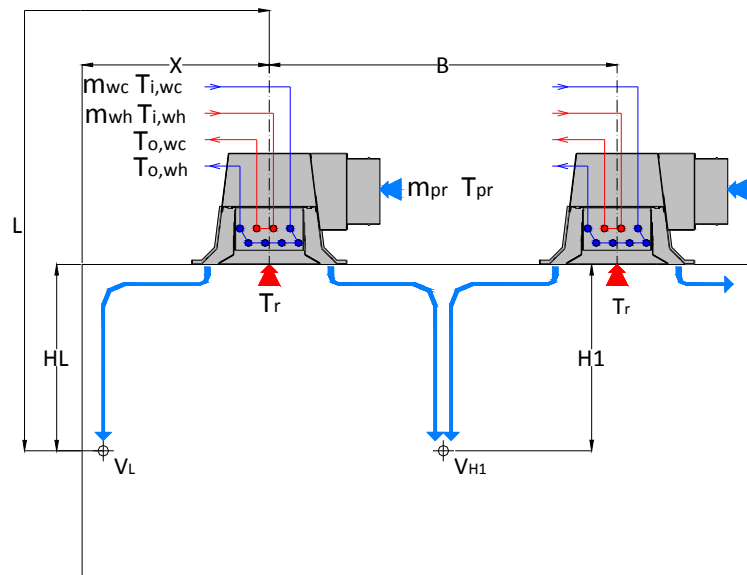
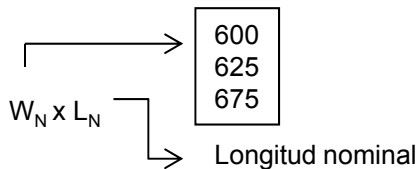

V_{H1}	(m/s)	Air speed at H_1 height
V_L	(m/s)	Air speed at L height
H_1	(m)	Distance from ceiling to living area (1.8 m)
B	(m)	Distance between two chilled beams
L_N	(m)	Nominal length of chilled beam
L_{WA}	(dBA)	Sound power level
P	(W)	Total power ($P=P_{pr} + P_{w,r}$)
P_{pr}	(W)	Primary airflow rate
P_w	(W)	Nominal water cooling or heating power
$P_{w,r}$	(W)	Water cooling or heating power
m_{pr}	(m^3/h)	Primary airflow volume
m_{wh}	(l/h)	Hot water flow volume
m_{wc}	(l/h)	Cold water flow volume
T_{pr}	($^{\circ}C$)	Primary air temperature
T_R	($^{\circ}C$)	Premises benchmark temperature
$T_{i,wc}$	($^{\circ}C$)	Cold water temperature at battery input
$T_{o,wc}$	($^{\circ}C$)	Cold water temperature at battery output
$T_{i,wh}$	($^{\circ}C$)	Hot water temperature at battery input
$T_{o,wh}$	($^{\circ}C$)	Hot water temperature at battery output
P_a	(Pa)	Static pressure inside plenum
ΔP_w	(kPa)	Pressure drop in water circuit
Δt_{aw}	($^{\circ}C$)	Difference in premises benchmark temperature and supply water temperature ($\Delta t_{aw}= T_R - T_{i,w}$)
Δt_{pr}	($^{\circ}C$)	Difference in premises benchmark temperature and primary supply air temp. ($\Delta t_{pr}= T_R - T_{pr}$)
F_w		Correction factor of water rate based on water flow volume ($P_{w,r}=P_w \cdot F_w$)
Δt_w	($^{\circ}C$)	$^{\circ}C$ Thermal gradient in battery

The nominal working conditions for WAAB 600 4 WAY chilled beams are as follows :

Cooling 2 and 4 tubes		Heating 2 tubes		Heating 4 tubes	
T_R	26 $^{\circ}C$	T_R	22 $^{\circ}C$	T_R	22 $^{\circ}C$
m_{wc}	170 l/h	m_{wc}	170 l/h	m_{wc}	80 l/h
$T_{i,wc}$	16 $^{\circ}C$	$T_{i,wc}$	35-40 $^{\circ}C$	$T_{i,wc}$	35-40 $^{\circ}C$
T_{pr}	16 $^{\circ}C$	T_{pr}	22 $^{\circ}C$	T_{pr}	22 $^{\circ}C$

(1) The recommended flow volume will maintain a thermal gradient of 3-4 $^{\circ}C$ in the battery.

(2) We recommend using a supply water temperature of 14-16 $^{\circ}C$ to avoid condensation.

(3) We recommend using a supply water temperature of 35-40 $^{\circ}C$ to avoid air stratification.