

**OTO**

**Curved Slot Architectural Swirl Diffusers**







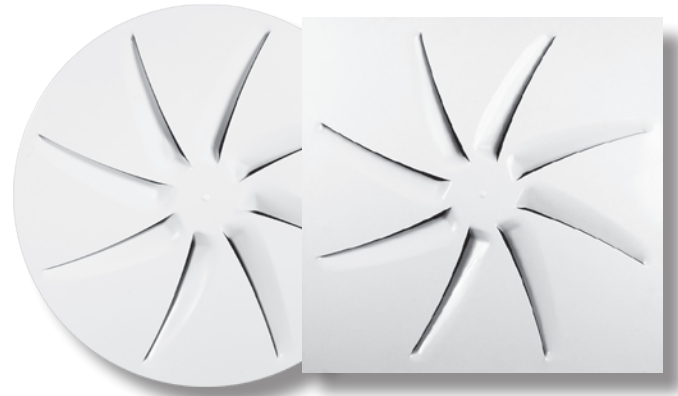





## OTO SERIES

### Curved Slot Swirl Diffusers



**OTO-C & OTO-S**  
by MADEL®

**PATENTED**

-  Fixed and reliable high induction swirl pattern
-  High velocity swirl jets provide efficient mixing of supplied air with room air
-  High tolerance to air entering the diffuser at an angle
-  Architecturally appealing curves and design
-  Great for lower cfm or high comfort applications
-  Square and round shapes available
-  Lay-in, duct mounted or drywall mounted, suitable for all ceilings
-  Single piece, heavy-gauge stamped steel face construction
-  Matching high-performance PERFAIR plenums, choice of top or side connection
-  PERFAIR have built-in anti-seismic attachment tabs and air equalizer/volume damper

OTO Series curved slot swirl diffusers by EffectiV HVAC™ and MADEL® are designed to be used in air conditioning, ventilation and heating systems at a temperature differential up to 22°F (12°C). They can be mounted in false ceilings, on drywall, or suspended from the ceiling, from 8.5 feet to 13 feet (2.6 up to 4 meters) high. OTO diffusers allow a flow variation of 60% while keeping the air stream stable.

The particular design of OTO diffusers creates a uniform airflow along the length of each aperture. The radial configuration of the eight curved slots produces a rotational blade jet pattern. The resulting high velocity swirl diffusion combined with a Coanda effect results in efficient mixing of supplied air with room air, a high induction ratio and reduced air stratification.

As a result of the collaboration with Lievore, Altherr & Molina, OTO's original design allows for manufacturing from a single continuous sheet, without any edges highlighting an assembled construction. This results in very smooth airflow characteristics while creating new design possibilities and reducing the visual impact within the architectural surroundings.

## Some Applications



Ideal for medium to low cfm applications where a high level of comfort is required



Ideal when reliable performance is required despite installation constraints



Closed office space, reception desk, waiting rooms, meeting rooms



High end residential applications



Restaurant dining rooms



Childcare



Schools and classrooms



Call centers



Dental and medical clinics



Multi-purpose rooms



## Plenum Selection

OTO swirl diffusers are available with a wide selection of PERFAIR plenums to suit any type of application. PERFAIR-SS with side connection is the most popular plenum for Square Diffusers and only requires 14" of ceiling space.

All PERFAIR plenums come with antiseismic tabs and perforated air volume damper / air equalizer.

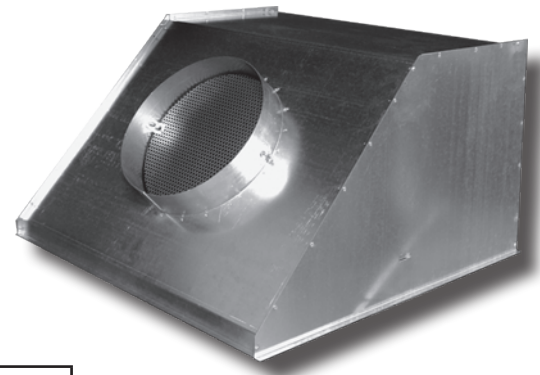

**PERFAIR-SS**

Plenum Model	Face Type	Connection	Recommended For
PERFAIR-CS	Round	Side	False or closed ceiling
PERFAIR-CT	Round	Top	Open ceiling with visible duct coming from top
PERFAIR-SS	Square	Side, Angle	False or closed ceiling
PERFAIR-SSS	Square	Side	Open ceiling with visible duct coming from side
PERFAIR-ST	Square	Top	Open ceiling with visible duct coming from top
PERFAIR-XS	Square	Side, Oval	Very limited ceiling space (6" min)
PERFAIR-XSS	Square	Side, Rect.	Very limited ceiling space (5" min)

## Integrated Air Volume Dampers

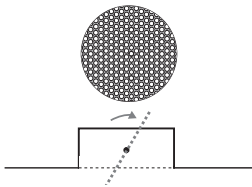

**R**

Perforated damper + air equalizer (Standard)

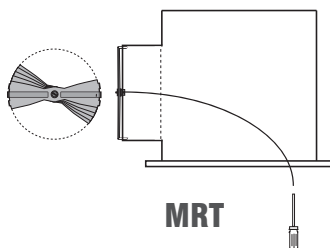

**MRT**

Manually operated damper, cable inside the plenum, adjustment through face

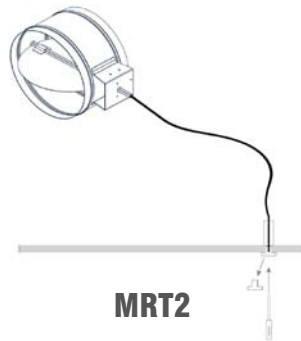

**MRT2**

Manually operated damper, cable through wall with termination fixture

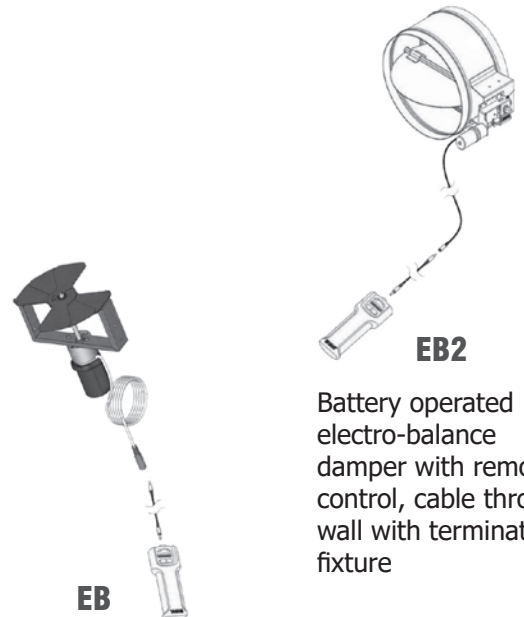

**EB**

Battery operated electro-balance damper with remote control, cable through face

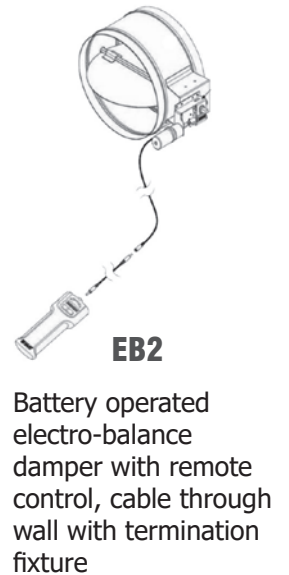

**EB2**

Battery operated electro-balance damper with remote control, cable through wall with termination fixture

### OTO-C Curved Slot Round Swirl Diffuser

Dim	Free Area (sqf)	Min cfm	Max cfm
25" (625mm)	0.0427	210	341



OTO-C

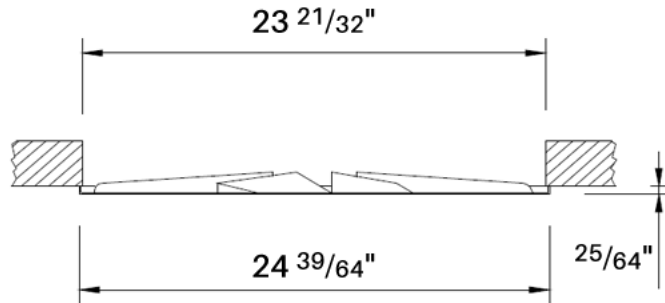

### OTO-C + PERFAIR Performance Data

24 5/8" Diameter Face (Imperial)

625mm Diameter Face (Metric)

Neck Size (inches)	Neck (fpm) Velocity	200	300	400	500	600	700	800	1000
	Velocity Pressure (H2O)	0.002	0.006	0.01	0.016	0.022	0.031	0.041	.062
6	CFM			79	98	118	137	157	196
	Pressure Loss (in.w.g.)			-	0.01	0.02	0.03	0.03	0.05
	NC			< 15	< 15	< 15	< 15	< 15	18
	Throw (ft) - Coanda Effect			2-3-3	2-3-4	2-3-5	2-4-6	3-4-6	3-5-8
	Throw (ft) - No Ceiling Effect			1-2-3	1-2-3	1-2-7	2-3-4	2-3-5	2-4-6
8	CFM		105	140	175	209	244	279	349
	Pressure Loss (in.w.g.)		0.02	0.03	0.04	0.06	0.08	0.1	0.16
	NC		< 15	< 15	15	19	24	27	33
	Throw (ft) - Coanda Effect		2-3-4	2-4-6	3-5-7	3-6-8	4-6-10	4-7-11	6-9-14
	Throw (ft) - No Ceiling Effect		1-2-3	2-3-4	2-4-5	3-4-6	3-5-7	3-6-8	4-7-10
10	CFM	109	164	218	273	327	382	436	545
	Pressure Loss (in.w.g.)	0.017	0.038	0.065	0.099	0.139	0.186	0.239	0.364
	NC	< 15	< 15	21	27	31	36	39	45
	Throw (ft) - Coanda Effect	2-3-4	3-4-7	4-6-9	4-7-11	5-9-13	6-10-15	7-12-17	9-14-22
	Throw (ft) - No Ceiling Effect	1-2-3	2-3-5	3-4-7	3-5-8	4-7-10	5-8-11	5-9-13	6-11-16

**Performance Notes**

- NC Value based on 10 db room attenuation.
- Throw Values are based on isothermal air and terminal velocities of **100 fpm, 60 fpm and 40 fpm** respectively.

### OTO-C + PERFAIR Performance Data (continued)

Damper Correction Factor		100% Open	50% Open	10% Open
25" D (625mm)	Pressure Loss	x1	x1.2	x3.1
	NC	+0.8	+2.7	-0.6

Delta T Correction Factors		
Δ T (F)	Kh	KI
0	0.04	1
-2	0.045	0.945
-4	0.05	0.91
-6	0.055	0.87
-8	0.06	0.84
-10	0.068	0.82
-12	0.076	0.805
-15	0.089	0.78

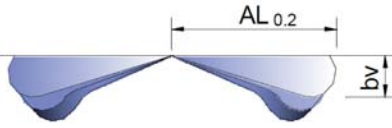

$bv = kh \times \text{Throw}$

$\text{Throw}'(\Delta T) = KI \times \text{Throw}$

Kh = Correction Factor for Vertical Diffusion  
 KI = Throw Correction Factor  
 AL<sub>0.2</sub> = Distance at which velocity reaches 40 fpm

Ratios		
Throw (ft)	i	Delta T Ratio
4	7	0.12
6	12	0.057
8	14	0.04
10	18	0.029
15	28	0.017
20	38	-
25	47	-
30	58	-

**induced room air = supplied cfm \* i**

induced room air = cfm mixed for given throw

---

**Delta T (Throw) = Delta T (Supply) \* Delta T Ratio**

Delta T (Supply) = T (Room) - T (Supply)  
 Delta T (Throw) = T (Room) - T (Throw)

### How to Specify OTO-C

Supply and mounting of round high induction OTO-C swirl diffuser, with stamped curved slots in radial pattern, dimension 25 inches or 625 mm. Constructed from galvanized steel face panel powder coated in white M9016. Shall be supplied and installed with PERFAIR high performance plenum box featuring integrated air equalizer and volume damper, security tabs, crossbar and long screw for easy face attachment. By EffectiV HVAC / MADEL.

### OTO-S Curved Slot Square Swirl Diffuser

Dim	Free Area (sqf)	Min cfm	Max cfm
24" x 24" (605mm)	0.0427	210	341



OTO-S

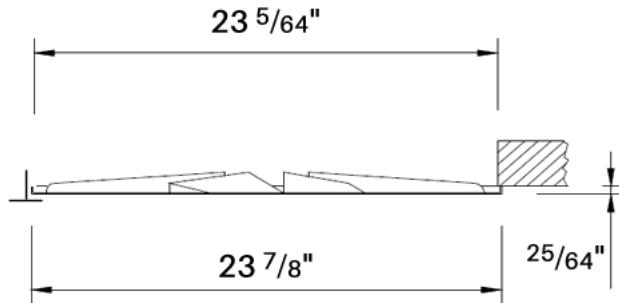

### OTO-S + PERFAIR Performance Data

24" x 24" Face (Imperial)

605mm x 605mm Face (Metric)

Neck Size (inches)	Neck (fpm) Velocity	200	300	400	500	600	700	800	1000
	Velocity Pressure (H2O)	0.002	0.006	0.01	0.016	0.022	0.031	0.041	.062
6	CFM			79	98	118	137	157	196
	Pressure Loss (in.w.g.)			-	0.01	0.02	0.03	0.03	0.05
	NC			< 15	< 15	< 15	< 15	< 15	20
	Throw (ft) - Coanda Effect			2-3-3	2-3-4	2-3-5	2-4-6	3-4-6	3-5-8
	Throw (ft) - No Ceiling Effect			1-2-3	1-2-3	1-2-7	2-3-4	2-3-5	2-4-6
8	CFM		105	140	175	209	244	279	349
	Pressure Loss (in.w.g.)		0.02	0.03	0.04	0.06	0.08	0.1	0.16
	NC		< 15	< 15	17	22	26	30	36
	Throw (ft) - Coanda Effect		2-3-4	2-4-6	3-5-7	3-6-8	4-6-10	4-7-11	6-9-14
	Throw (ft) - No Ceiling Effect		1-2-3	2-3-4	2-4-5	3-4-6	3-5-7	3-6-8	4-7-10
10	CFM	109	164	218	273	327	382	436	545
	Pressure Loss (in.w.g.)	0.017	0.038	0.065	0.099	0.139	0.186	0.239	0.364
	NC	< 15	16	23	29	34	38	41	47
	Throw (ft) - Coanda Effect	2-3-4	3-4-7	4-6-9	4-7-11	5-9-13	6-10-15	7-12-17	9-14-22
	Throw (ft) - No Ceiling Effect	1-2-3	2-3-5	3-4-7	3-5-8	4-7-10	5-8-11	5-9-13	6-11-16

**Performance Notes**

- NC Value based on 10 db room attenuation.
- Throw Values are based on isothermal air and terminal velocities of **100 fpm, 60 fpm and 40 fpm** respectively.

### OTO-S + PERFAIR Performance Data (continued)

Damper Correction Factor		100% Open	50% Open	10% Open
24"x 24" (605mm)	Pressure Loss	x1	x1.2	x3.1
	NC	+0.8	+2.7	-0.6

Delta T Correction Factors		
Δ T (F)	Kh	KI
0	0.04	1
-2	0.045	0.945
-4	0.05	0.91
-6	0.055	0.87
-8	0.06	0.84
-10	0.068	0.82
-12	0.076	0.805
-15	0.089	0.78

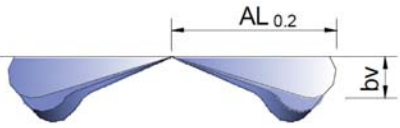

$bv = kh \times \text{Throw}$

$\text{Throw}'(\Delta T) = KI \times \text{Throw}$

Kh = Correction Factor for Vertical Diffusion  
 KI = Throw Correction Factor  
 AL<sub>0.2</sub> = Distance at which velocity reaches 40 fpm

Ratios		
Throw (ft)	i	Delta T Ratio
4	7	0.12
6	12	0.057
8	14	0.04
10	18	0.029
15	28	0.017
20	38	-
25	47	-
30	58	-

**induced room air = supplied cfm \* i**

induced room air = cfm mixed for given throw

---

**Delta T (Throw) = Delta T (Supply) \* Delta T Ratio**

Delta T (Supply) = T (Room) - T (Supply)  
 Delta T (Throw) = T (Room) - T (Throw)

### How to Specify OTO-S

Supply and mounting of high induction square swirl diffuser OTO-S, with stamped curved slots in radial pattern, dimension 24x24 inches or 605x605 mm. Constructed from galvanized steel face panel powder coated in white M9016. Shall be supplied and installed with PERFAIR high performance plenum box featuring integrated air equalizer and volume damper, security tabs, crossbar and long screw for easy face attachment. By EffectiV HVAC / MADEL.



## How to Order OTO Series

OTO	-S	24	+ PERFAIR-ST	24	10	
			<b>Plenum</b>	<b>Neck Diameter</b> 6" 8", 10" or 12" D		
				<b>Match Face Dim</b> Match Product Face		
				PERFAIR-CS	Round, Side Entry	
				PERFAIR-CT	Round, Top Entry	
			PERFAIR-SS	Square, Side Entry		
			PERFAIR-ST	Square, Top Entry		
<b>Face Dimension</b>			24	24"x24" Square Face		
			25	25" Diameter Face		
<b>Model</b>			C	Round		
			S	Square		



